

THIS DRAWING IS UNPUBLISHED. RELEASED FOR PUBLICATION
 © COPYRIGHT - By - ALL RIGHTS RESERVED.

LOC	DIST	REVISIONS					
		P	LTR	DESCRIPTION	DATE	DWN	APVD
G	14		E	REVISED PER ECO-14-015277	25FEB2015	NK	DR

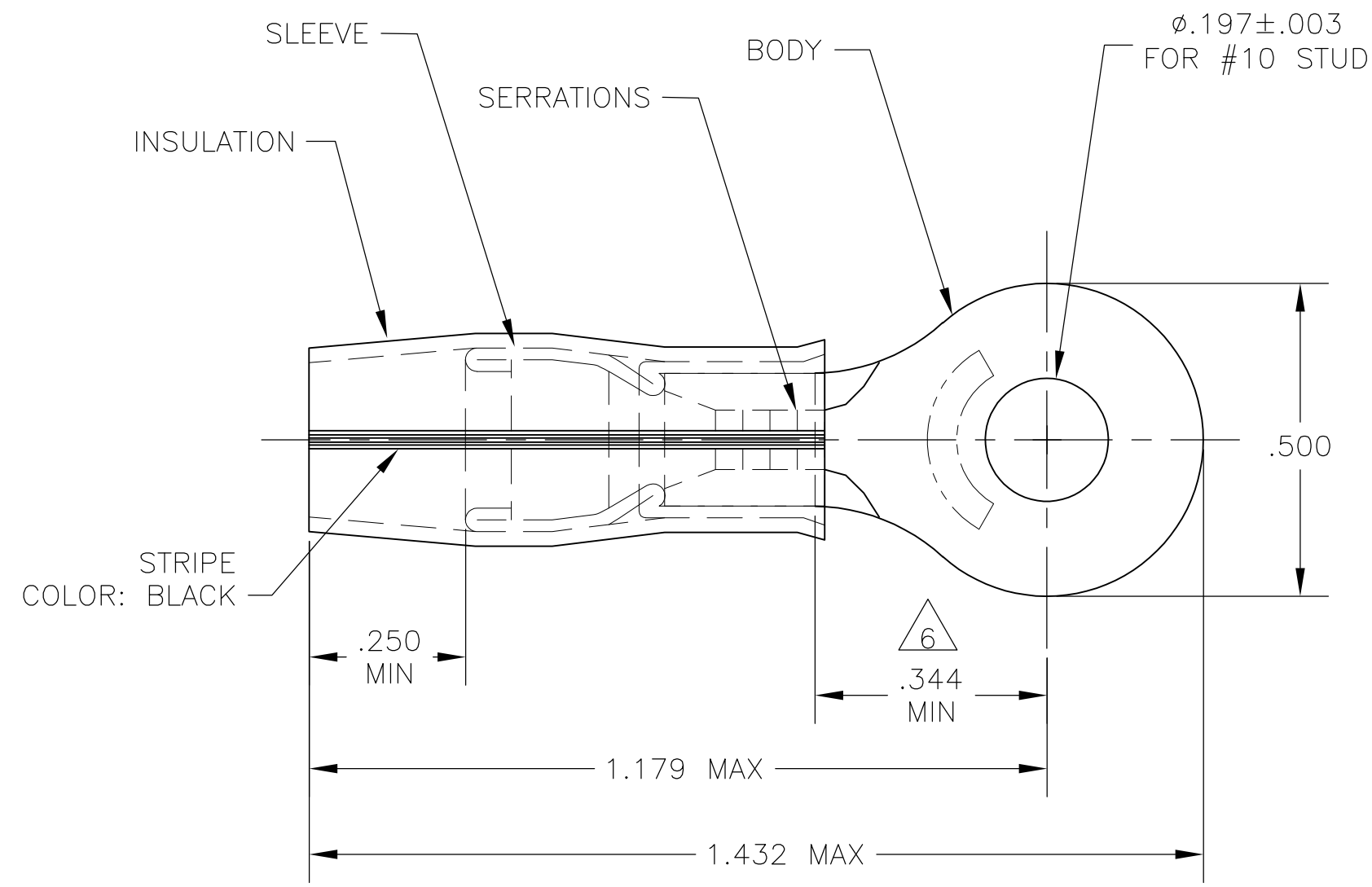

- 1 STAMP AMP 16-14 HD* APPROX AS SHOWN.
- 2 WIRE INSULATION DIA: .150-.220.
- 3 TONGUE MATERIAL THK: .048±.002.
- 4 BODY & SLEEVE: TIN PLATE PER ASTM B545.
- 5 BODY & SLEEVE- CU PER ASTM B152 INSULATION - NYLON, COLOR - YELLOW.
- 6 APPLIES FROM EDGE OF METAL WIRE BARREL TO CENTER OF STUD HOLE.

500	LOOSE PIECE	329391
QTY	PACKAGE TYPE	PART NO

AMP INCORPORATED
CUSTOMER SERVICE SYSTEMS

FOR ADDITIONAL PRODUCT INFORMATION OR COPIES OF DRAWINGS AND TECHNICAL DOCUMENTS
 PRODUCT INFORMATION CENTER
 1-800-522-6752

FOR APPLICATION TOOLING ASSISTANCE CENTER
 TOOLING INFORMATION
 1-800-722-1111

FOR ORDER ENTRY
 1-800-526-5142

MAX RECOMMENDED OPERATING TEMPERATURE:
 105°C MAX

VOLTAGE RATING:
 600 MAX

CIRCULAR MIL AREA:
 1.04-2.62mm² [2,050-5,180] STRANDED

THIS DRAWING IS A CONTROLLED DOCUMENT.

DIMENSIONS: INCHES

TOLERANCES UNLESS OTHERWISE SPECIFIED:

0 PLC	± -
1 PLC	± -
2 PLC	± -
3 PLC	± -
4 PLC	± -
ANGLES	± -
FINISH	± -

MATERIAL 5

DWN	JR RUTH	14SEP05
CHK	T MICHELUTTI	14SEP05
APVD	T MICHELUTTI	14SEP05
PRODUCT SPEC	-	
APPLICATION SPEC	-	
WEIGHT	-	

STE TE Connectivity

NAME: TERMINAL, RING TONGUE, P.I.D.G.
 WIRE SIZE: 16-14 HD AWG

SIZE	CAGE CODE	DRAWING NO	RESTRICTED TO
A3	00779	C-329391	-

CUSTOMER DRAWING SCALE 4:1 SHEET 1 OF 1 REV E